

AQUABAR® "B"

TILE & FLOORING UNDERLAYMENT

In the battle against interior moisture damage, the best defense is a strong offense. When you block moisture vapor from creeping behind finish materials or reaching moisture-sensitive substrates, you help increase the useful life and appearance of finish surfaces. To help win the battle, the

“*An extremely effective moisture vapor retarder for use in a variety of interior construction applications.*”

Fortifiber Building Systems Group® offers Aquabar “B” as inexpensive insurance to reduce moisture-related problems.

Aquabar “B” floor and tile underlayment is an extremely effective moisture vapor retarder for use in a variety of interior

construction applications. Consisting of two layers of kraft paper laminated with asphalt, Aquabar “B” is a non-reinforced 30/30/30 duplex type Grade “B” paper.

An Investment That Pays Dividends

Aquabar “B” is often considered to be cleaner and easier to work with than other materials, such as roofing felt and poly film. Because it is an effective moisture vapor retarder, Aquabar “B” reduces vapor migration to help protect wood floors, tile substrates, and floor and wall cavities from the damaging effects of moisture.

Ideal for Wood Flooring and Tile

With a moisture vapor permeance of less than 1, Aquabar “B” is a superior vapor retarder under wood flooring applications. Aquabar “B” helps slow moisture vapor originating below the floor system, allowing the wood flooring to acclimate gradually. By reducing the rate of moisture migration, Aquabar “B” protects against moisture vapor related floor problems such as buckling, cupping or cracking. As a semi-permeable material, Aquabar “B” is much less likely than common poly film to trap moisture condensation between it and the sub-floor. Aquabar “B” also acts as a “slip sheet” to minimize dust and reduce noise.

Aquabar “B” is also suitable in interior tile and stone applications as a moisture retardant membrane (or cleavage membrane) on walls, countertops, or residential showers for use behind cement backer units. It is also suitable for use as a cleavage membrane in mortar bed applications over wood or concrete substrates. Aquabar “B” reduces the potential for and extent of damage caused by moisture vapor migration in tile installations.

Decades of Proven Performance

Aquabar “B” is a product manufactured by the Fortifiber Building Systems Group. With more than a seventy year history of proven performance, technical expertise and practical know-how, the company has become a trusted partner to builders, architects and code officials.



- HIGH MOISTURE RESISTANCE
- LOW VAPOR PERMEANCE
- 30/30/30 CONSTRUCTION
- CLEAN & EASY INSTALLATION

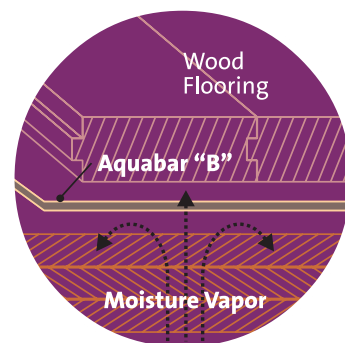

Aquabar “B” helps slow moisture vapor originating below the wood floor system.

Product Description: Aquabar "B" is a semi-permeable Class II vapor retarder or cleavage membrane for use under wood floor installations and behind or below tile substrates. Aquabar "B" is rated for "moderate" water-vapor resistance.

Composition: Aquabar "B" is a 30/30/30 Grade B asphalt laminated duplex type kraft paper.

Size & Weight: Aquabar "B" is supplied in 36" wide by 167' lineal feet (500 sq. ft.) and 334' lineal feet (1000 sq. ft.) rolls; product weight is approximately 3 lbs/100 sq. ft.

Applicable Standards: Meets the 2009 International Residential Code as a Class II "vapor retarder".

Meets ANSI A108.01 Sec. 3.3.3.1 General Requirements: Subsurfaces and Preparations by Other Trades.

Meets ANSI A108.02 Sec. 3.8.7 Materials, Environmental & Workmanship.

Exceeds Federal Specification UU-B-790a, Type I, Grade B, Style 1a.

American Society for Testing & Materials (ASTM)

- ASTM D-779 - Standard Test Method For Water Resistance of Paper, Paperboard and Other Sheet Materials by the Dry Indicator Method
- ASTM D-828 - Tensile Properties of Paper and Paperboard Using Constant-Rate-of-Elongation Apparatus
- ASTM E-96 - Water Vapor Transmission of Materials

Physical Properties: Aquabar "B" is continually tested in accordance with ASTM procedures. The values shown in Table 1 are averages obtained in these tests.

Limitations: Aquabar "B" tile and flooring underlayment is not a waterproof membrane and should not be used in waterproofing assemblies or where a waterproof membrane is specified. Do not leave exposed to direct moisture contact or use in areas that are soaked or saturated for extended periods of time, such as gang showers, saunas, steam rooms, hot tubs and exterior areas. Aquabar "B" has little or no noticeable odor, it does contain asphalt, individual sensitivity to chemicals varies and should be considered prior to purchase of any product. Aquabar "B" may be used as a vapor retarder over a radiant heat substrate as long as the substrate temperature is limited to a maximum 80°F. Not recommended for use on exterior surface of studs in wall assemblies as a weather resistant barrier. Properly prepared walls, sub-floors or job site conditions and proper installation of flooring and tile are the responsibility of the installer. In applications where a duplex type reinforced asphalt paper, meeting ASTM C-171, is specified use Fortifiber's Orange Label Sisalkraft®.

Installation - General: Cut Aquabar "B" to length as required for proper coverage and overlap all seams a minimum of 4 inches. Sweep sub-floors of debris to avoid tearing or puncturing. Avoid puncturing Aquabar "B" except with required fasteners.

Installation - Wood Floors: For wood flooring installations, follow the wood flooring manufacturer's instructions, NWFA Installation Guidelines, and local building codes for proper installation of wood flooring over the sub-floor. Concrete or wood sub-floor must be dry and tested for moisture, flat with high spots sanded and low spots filled, structurally sound, and free of protrusions, debris or contaminants.

For concrete sub-floors, ensure that an underslab vapor retarder has been properly installed beneath the concrete slab, such as Fortifiber's Moistop Ultra® family of products. For installations above a crawl space, make sure the ground has been properly covered by a Class I vapor retarder with a minimum perm rating of 0.1 or less and the crawl space is properly cross vented or meets code requirements as a closed crawl space. Over a concrete sub-floor with a "floating wood floor system" or screed system, apply Fortifiber's Moistop Ultra® 6 as the required Class I vapor retarder between concrete and plywood. Then install Aquabar "B" over the plywood followed by the wood flooring.

Installation - Tile: Aquabar "B" may be installed on interior walls, floors, and countertops where a moisture retarding cleavage membrane is specified or required by code. Read and follow the architect/specifier's installation instructions or applicable ANSI A108 installation procedures as referenced by the TCNA Handbook for ceramic tile installation. Aquabar "B" is not a waterproof membrane.

Availability: The Fortifiber Building Systems Group's products are distributed nationwide. For product information and pricing, please call a Fortifiber distributor near you. If you need assistance locating a participating distributor, please call our Customer Service Department at 1-800-773-4777.

Warranty: Fortifiber Corporation warrants that its products are in compliance with their published specifications and are free from defects in materials and workmanship for a period of two years from the date of purchase. This warranty does not apply to loss due to abuse. Material found to be defective will be replaced at no charge by Fortifiber, but in no event shall Fortifiber be liable for any other costs or damages, including any labor costs.

THIS EXPRESS WARRANTY IS GIVEN IN LIEU OF AND EXCLUDES ALL OTHER EXPRESS OR IMPLIED WARRANTIES, INCLUDING BUT NOT LIMITED TO THE IMPLIED WARRANTIES OF MERCHANTABILITY AND FITNESS FOR A PARTICULAR PURPOSE. Fortifiber's sole obligations under this warranty are as set forth herein. In no event shall Fortifiber be liable for any lost revenue or profits, direct, indirect, special, incidental or consequential damages of any kind.

SPECIFICATION SUMMARY: Provides moderate moisture and moisture vapor retarder underlayment beneath wood flooring, ceramic tile and stone veneer.

MOISTURE VAPOR RETARDER: Fortifiber/Aquabar "B" two-layer, asphalt laminated kraft Grade B paper.

REFERENCE SPECIFICATION: Federal Specification UU-B-790a, Type 1, Grade B, Style 1a.

Table 1- Physical Properties

CHARACTERISTIC	TEST METHOD	RESULTS	INDUSTRY STANDARD
Water Vapor Transmission	ASTM E-96 (A)	< 1 perm	< 1 perm
Water Resistance	ASTM D-779	16+ hours	16 hours (min.)
Tensile Strength	ASTM D-828	MD - 20 lb. ^f /inch CD - 20 lb. ^f /inch	MD - 20 lb. ^f /inch CD - 20 lb. ^f /inch



Fortifiber Building Systems Group®
Protecting Your World from the Elements®

Call 1-800-773-4777 or 1-775-333-6400 for sales and technical assistance. On the Internet visit www.fortifiber.com.

© 2011 Fortifiber Building Systems Group. Fortifiber®, Aquabar® "B", Orange Label Sisalkraft®, Moistop Ultra® and Protecting Your World from the Elements® are trademarks of Fortifiber Corporation. 02/11

APPLICATIONS FOR AQUABAR® "B" UNDERLAYMENT MEMBRANE

THE DETAILS SHOWN HERE REFER TO GENERALLY ACCEPTED
WOOD FLOOR INSTALLATION PRACTICES

Aquabar "B" is an extremely effective moisture vapor retarder for use under wood flooring. It is a cleaner and easier handling product than roofing felt and poly film. Aquabar "B" slows moisture migration and is a superior vapor retarder. **It is not a waterproof membrane.**

HARDWOOD FLOORS

Under wood floors, **Aquabar "B"** serves as a moisture and vapor retarder, reducing or preventing moisture migration from below the floor system, allowing the wood flooring to acclimate gradually. As a semi-permeable material, **Aquabar "B"** is also much less likely than poly film to trap moisture condensation between it and the sub-floor. Installed under wood floors as a "slip sheet", Aquabar "B" helps keep down dust and reduces squeaks.

This application guide provides examples of typical wood flooring installations using **Aquabar "B"**. The descriptions are brief and do not cover all circumstances that the installer may encounter during installation. It is the responsibility of the installer to read and follow the flooring manufacturer's complete instructions for proper installation of their flooring. Aquabar "B" may be used in applications over a wood or concrete sub-floor.

JOB SITE CONDITIONS

- Building must be completely enclosed
- Site drainage directs water away from foundation
- All other interior work should be completed
- Interior environmental conditions must be at occupied levels
- Basements and crawl spaces must be dry
- Acclimate flooring per manufacturer's recommendation

SUB-FLOOR PREPARATION

- All surface debris and protrusions must be removed
- Check sub-floor for squeaks and repair
- Sweep and vacuum prior to filling or repairing voids
- Fill voids and level high spots, sweep again

WOOD SUB-FLOORS – NAILED

Always read and follow the floor manufacturer's installation instructions. For installations over wood joist construction be sure, if above a crawl space, the ground is covered by a vapor retarder with a perm rating of ≤ 0.1 , such as Fortifiber's **Moistop Ultra**, and crawl space is properly ventilated. Cut **Aquabar "B"** to length and position over sub-floor as needed for proper

coverage. Overlap edge seams a minimum of 4 inches. Once **Aquabar "B"** is installed, snap chalk lines to desired layout.

CONCRETE SUB-FLOORS – FLOATED & NAILED

For on-grade slabs, the following conditions must be met:

- An underslab vapor retarder has been properly installed, such as Fortifiber's **Moistop Ultra** family of products.
- The slab is thoroughly dry before installation of wood flooring. Generally, slabs must be 60 days old. Test for moisture, following flooring manufacturer's recommendations.
- To be certain normal slab moisture does not reach the wood flooring, install a vapor retarder with a perm rating of ≤ 0.1 – such as Fortifiber's **Moistop Ultra** – over the slab.

Then follow wood floor manufacturer's recommendation for placement of plywood. Cut and install **Aquabar "B"** over plywood as above.

CONCRETE SUB-FLOORS – SCREED SYSTEM

Install flat, dry, preservative treated 2x4s, cut 18-24" long, laid flat at right angles to finished floor, spaced 12" o.c. and embed in adhesive. Then lay a vapor retarder with a perm rating of ≤ 0.1 over screeds, install plywood and cover with **Aquabar "B"** as above.

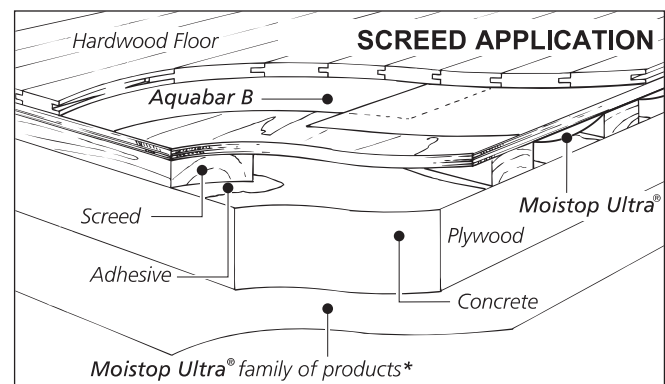
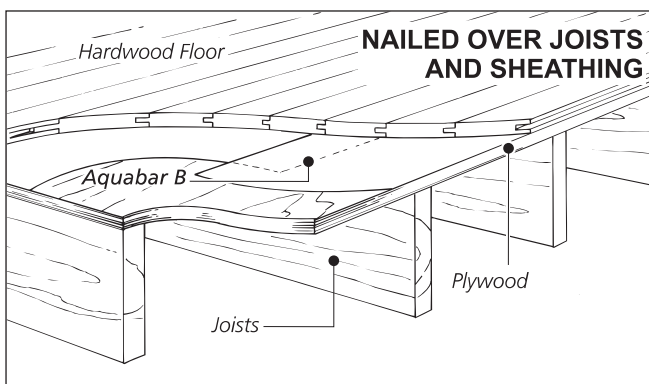
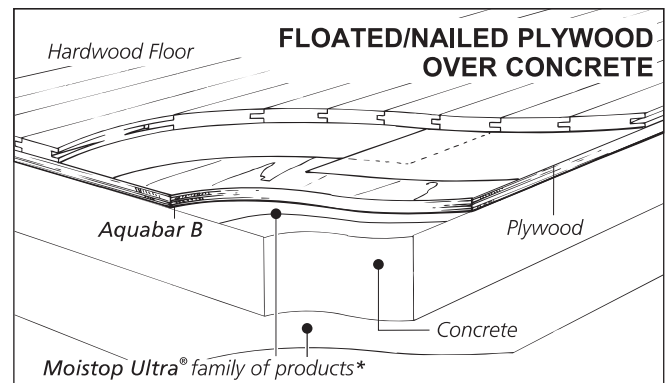

***The Moistop Ultra® family of underslab vapor retarders are critical for Wood and Tile floors placed on concrete slabs.**

APPLICATIONS FOR AQUABAR® “B” TILE & FLOORING UNDERLAYMENT

THE DETAILS SHOWN HERE REFER TO GENERALLY ACCEPTED
TILE INSTALLATION PRACTICES

Aquabar “B” is suitable for use in interior tile and stone applications as a moisture retardant membrane, or cleavage membrane on walls, countertops, or residential showers. It reduces the potential for damage caused by moisture vapor migration. **Aquabar “B” is not a waterproof membrane** and should not be used in waterproofing assemblies or where a waterproof membrane is specified.

TILE & STONE INSTALLATIONS

The following illustrations are examples of typical tile and stone installations using **Aquabar “B”**. The following illustrations are designed to show the positioning of **Aquabar “B”** within the assembly and do not attempt to give step-by-step installation details for the assembly. To obtain detailed installation instructions, please refer to the Handbook for Ceramic Tile Installation, “The Industry’s Guide for Installation Practices”, or ANSI Standards. Contact The Tile Council of North America, Inc., on-line at tileusa.com or call (864) 646-8453.

All tile applications should be installed in accordance with appropriate ANSI A108, A118 and A136 standards for installation of ceramic tile, the architect/specifier instructions and all local building codes. When installing behind a cementitious backer

units follow the CBU manufacturer’s installation instructions for a moisture retardant barrier. In applications where a duplex type reinforced asphalt paper meeting ASTM C-171 is specified, use Fortifiber’s **Orange Label Sisalkraft** paper.

INSTALLATION – Cut **Aquabar “B”** to length and position over substrate as needed for proper coverage. It may be applied to wall framing either horizontally (best method) or vertically. Overlap seams a minimum of 4 inches or more as required by CBU manufacturer or architect/specifier and local building codes. Be sure to overlap tub or shower lip and seal gap between the tile installation and tub/shower unit with a high quality elastomeric caulking after tile work and grout are dry.

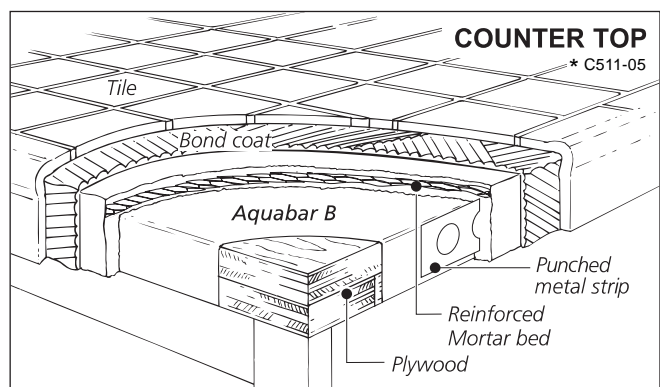
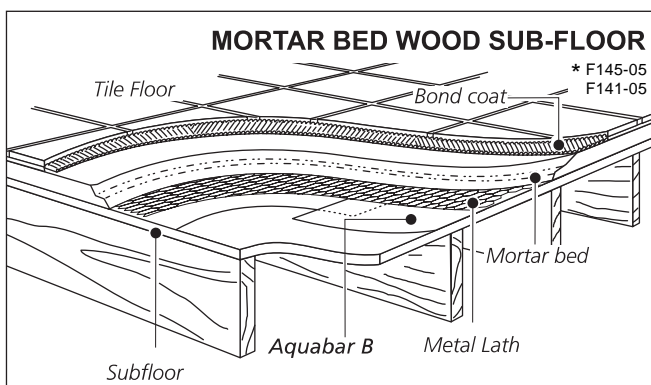
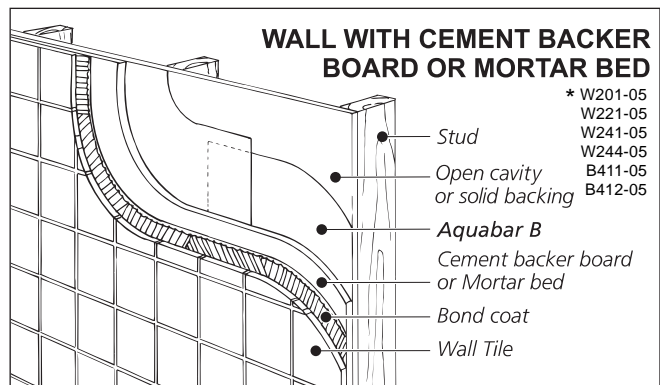
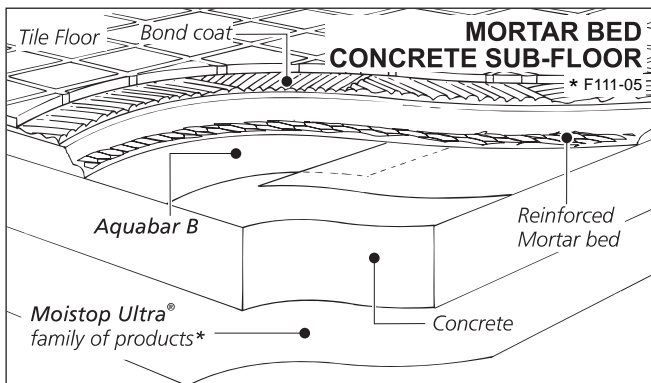

LIMITATIONS: **Aquabar “B”** tile and floor underlayment is not a waterproof membrane and should not be used in waterproofing assemblies where a waterproof membrane is specified. Do not leave exposed to direct moisture contact or use in areas that are soaked or saturated for extended periods of time, such as gang showers, saunas, steam rooms, pools, hot tubs and exterior areas. Not recommended over radiant heat systems, which may result in asphalt odor. Not recommended for use in exterior wall assemblies. Properly prepared walls, sub-floors or jobsite conditions and proper installation of flooring and tile are the responsibility of the installer. In applications where duplex type reinforced asphalt paper, meeting ASTM C-171, is specified use Fortifiber’s **Orange Label Sisalkraft**.

*See current Handbook for Ceramic Tile for installation details.

Call 1-800-773-4777 Nationwide for
Technical Assistance or visit our website
at www.fortifiber.com



**Fortifiber Building
Systems Group®**

Protecting Your World from the Elements®

NATIONAL SALES OFFICE – Fernley, NV

(577/10)