

Features

- Twelve Oaks signature luxurious hardwood flooring. Hand-stained and crafted to perfection by skilled artisans.
- Finished with aluminum oxide UV coating, but has the oil-finished matte look. Small-batch production.
- Indoor Air Quality and Formaldehyde Emission tests: FloorScore certified, CARB 93120 Phase 2 and EPA 40 C.F.R. 770 compliant

Product Information

Product Line	Master Artisan Engineered Hardwood Flooring
Construction	Tongue and Groove
Wood Species	Hickory, Ash, Canadian Hard Maple, and White Oak
Dimensions	7.5" x 5/8" x mostly 75" long boards Canadian Hard Maple: Varigated widths 6-1/4", 7-1/2", 8-5/8"
The Look	ThruColor™, Smoked, Whitewashed, Handscraped and/or Wirebrushed
Veneer and Finish	Hand stained and finished with Aluminum Oxide topcoat
Sawn method	Sawn cut, 4mm solid wood veneer
Warranty	5-Year Light Commercial and 35-Year Residential Limited Warranty
Installation	Please refer to Installation Instruction, Care and Maintenance Guide

Essential Characteristics

Characteristics	Test Method	Requirement	Our products test result
Reaction to fire	EN13501-1	National requirement	Class C fl-s1
Content of pentachlorophenol	CEN/TR 14823	No content allowed	No content
Slip resistance	EN 13893	Class DS: $\mu \geq 0.30$	DS
Formaldehyde Emission	EN 717-1	≤ 0.5 mg/L	Pass

Classification Requirements

Characteristic	Test Method	Valuation
Effect of a furniture leg	EN 424	We recommend the use of protective mats
Effect of castor chair	EN 425	We recommend using felt pads under all furniture legs
Chemical resistance	EN 13442	Category 5
Bond strength/gross cut test	ISO 2409	Category 0
Moisture content	EN 13489	6-9%

Tolerance

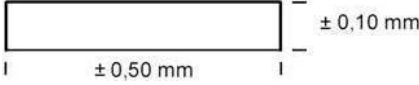
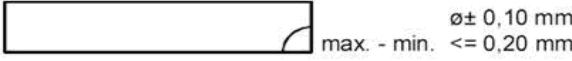
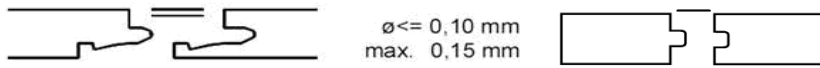
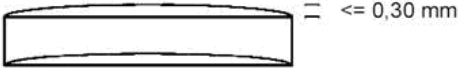
Thickness Variance	≤0.5mm
Openings between join panels	≤0.15mm
Dimension Tolerance Length & Width (mm)	
Squareness (mm)	
Height Variation (mm)	
Edge Straightness (mm)	
Flatness	<p>Width Flatness, concave<0.15%, convex<0.20%</p> <p>Length Flatness, concave<0.50%, convex<1.0%</p>

Packaging Information

	Length (mm)	Width (mm)	Thickness (mm)	Sq. ft. per Carton	Weight (lb. per carton)
Plank (ENG610/611)	Assorted Lengths 630 - 1900	160/190/220	15		
Plank (ENG612-615)	Assorted Lengths 630 - 1900	190	15		
Plank (other)	Assorted Lengths 630 - 1900	190	15		
Carton (ENG610/611)	1905	385	50	23.5	39
Carton (ENG612-615)	1905	195	125	31.1	56
Carton (other)	1905	195	100	23.5	43

Pallet Information

	Length (mm)	Width (mm)	Height (mm)	Volume (m ³)	# of carton per Pallet	Sq. ft. /pallet	Weight (lb.)
Pallet (ENG610/611)	1905	1155	1150	2.53	63	1480.5	2457
Pallet (ENG612-615)	1905	975	1100	2.04	40	1244	2240
Pallet (other)	1905	975	1100	2.04	50	1175	2150