

Product Spec Sheet
Master Artisan Collection



Inspired by the magnificent flooring that once graced the finest European châteaux, Master Artisan retraced the patina onto our luxuriously wide planks. All of our woods are sustainably harvested from Europe, USA and Canada. Every color is sawn cut and uniquely hand-crafted in small batches by our skilled artisans. We apply state-of-the-art smoking, staining and finishing techniques to bring out the richest colors, textures and characters found only in real wood. Original design coupled with superior craftsmanship make our flooring the statement piece in any space.

Features	
<ul style="list-style-type: none"> • Twelve Oaks signature luxurious hardwood flooring. Hand-stained and crafted to perfection by skilled artisans. • Finished with aluminum oxide UV coating, but has the oil-finished matte look. Small-batch production. • Indoor Air Quality and Formaldehyde Emission tests: FloorScore certified, CARB 93120 Phase 2 and EPA 40 C.F.R. 770 compliant 	

Product Information

Construction	Profile	Wood Species	Dimension	The Look
Multi Layer Ply Core	Tongue and Groove	Hickory, White Oak, American Oak	White Oak: 5/8" x 7-1/2" x R.L. 9/16" x 7-1/2" x R.L. Mostly 75" long boards American Oak: 5/8" x 8-5/8" x 86-5/8" R.L. 50% full length boards Hickory: 5/8" x 7-1/2" x R.L. Mostly 75" long boards	Handscraped and/or Wirebrushed

Finish	Sawn Method	Residential Warranty	Commercial Warranty	Installation	Installation Instruction
Hand stained and finished with 7 Aluminum Oxide topcoats	Sawn Cut, 3mm solid wood veneer	35-Year Residential Limited Warranty	5-Year Light Commercial Warranty	Below, on or above grade	Please refer to Installation Instruction, Care and Maintenance Guide

Essential Characteristics

Characteristics	Test Method	Requirement	Our products test result
Reaction to fire	EN13501-1	National requirement	Class C fl-s1
Content of pentachlorophenol	CEN/TR 14823	No content allowed	No content
Slip resistance	EN 13893	Class DS: $\mu \geq 0.30$	DS
Formaldehyde Emission	ASTM D6007-2014	≤ 0.05 ppm	≤ 0.01 ppm, Pass

Classification Requirements

Characteristic	Test Method	Valuation
Effect of a furniture leg	EN 424	We recommend the use of protective mats
Effect of castor chair	EN 425	We recommend using felt pads under all furniture legs
Chemical resistance	EN 13442	Category 5
Bond strength/gross cut test	ISO 2409	Category 0
Moisture content	GB/T18103-2013	6-9%
Glue Bonding	GB/T18103-2013	1.41PMa

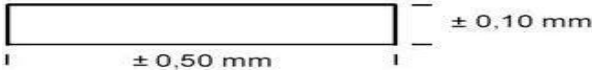
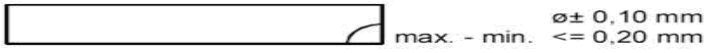
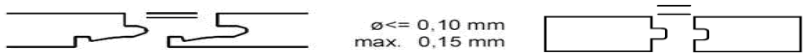
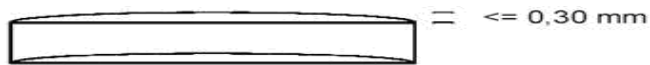
Tolerance	
Thickness Variance	≤0.5mm
Openings between join panels	≤0.15mm
Dimension Tolerance Length & Width (mm)	
Squareness (mm)	
Height Variation (mm)	
Edge Straightness (mm)	
Flatness	Width Flatness, concave<0.15%, convex<0.20% Length Flatness, concave<0.50%, convex<1.0%

Packaging Information					
	Length (mm)	Width (mm)	Thickness (mm)	Sq. ft. per Carton	Weight (lb. per carton)
9/16" W. Oak Plank	1900	190	14		
9/16" W. Oak Carton	1910	200	122	31.1	58
5/8" W. Oak Hickory Plank	1900	190	15		
5/8" W. Oak Hickory Carton	1910	200	100	23.5	47
American Oak Plank	2200	220	15		
American Oak Carton	2210	230	85	26.1	53

Pallet Information					
	Length Width Height (mm)	Volume (m³)	# of carton per Pallet	Sq. ft. /pallet	Weight (lb.)
9/16" W. Oak Pallet	1910 1000 1100	2.89	40	1244	2320
5/8" W. Oak Hickory Pallet	1910 1000 700	2.17	30	705	1410
American Oak Pallet	2210 1150 780	2.26	40	1044	2120