

Product Spec Sheet
Scandinavian Living Collection



Experience the essence of Scandinavian Living with our exceptional hardwood collection - the Scandinavian Living Collection. Immerse yourself in a world of captivating beauty, boasting breathtaking colors meticulously crafted to enhance any space. Discover Premium Grade American Oak options, meticulously selected for their low color variation, along with equally enchanting Maple and Hickory selections that effortlessly embrace the Scandinavian aesthetic. Elevate your space with Scandinavian Living floors and unlock a realm where style and durability intertwine, leaving an indelible mark of elegance that will stand the test of time. Experience the allure of Scandinavian Living today.

Features

- Twelve Oaks hallmark engineered hardwood flooring. Including five beautiful colours curated from Premium Grade American Oak and two equally unique Maple and Hickory selections.
- Indoor Air Quality and Formaldehyde Emission tests: FloorScore certified, CARB 93120 Phase 2 and EPA 40 C.F.R. 770 compliant.
- Finished with aluminum oxide UV coating.

Product Information

Construction	Profile	Wood Species	Dimension	The Look
Multi Layer Ply Core	Tongue and Groove	Hickory, Maple, American Oak	3/4" x 7-1/2" x R.L. (up to 75")	Wirebrushed



Finish	Sawn Method	Residential Warranty	Commercial Warranty	Installation	Installation Instruction
Hand stained and finished with 7 Aluminum Oxide topcoats	Sliced cut, 1.5mm solid wood veneer	35-Year Residential Limited Warranty	5-Year Light Commercial Warranty	Below, on or above grade	Please refer to Installation Instruction, Care and Maintenance Guide

Essential Characteristics

Characteristics	Test Method	Requirement	Our products test result
Reaction to fire	EN13501-1	National requirement	Class C fl-s1
Content of pentachlorophenol	CEN/TR 14823	No content allowed	No content
Slip resistance	EN 13893	Class DS: $\mu \geq 0.30$	DS
Formaldehyde Emission	ASTM D6007-2014	≤ 0.05 ppm	≤ 0.01 ppm, Pass

Classification Requirements

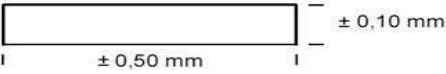
Characteristic	Test Method	Valuation
Effect of a furniture leg	EN 424	We recommend the use of protective mats
Effect of castor chair	EN 425	We recommend using felt pads under all furniture legs
Chemical resistance	EN 13442	Category 5
Bond strength/gross cut test	ISO 2409	Category 0
Moisture content	GB/T18103-2013	6-9%
Glue Bonding	GB/T18103-2013	1.41PMa

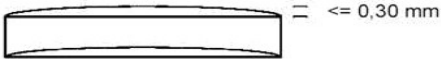
Tolerance	
Thickness Variance	≤0.5mm
Openings between join panels	≤0.15mm
Dimension Tolerance Length & Width (mm)	 ± 0,50 mm ± 0,10 mm
Squareness (mm)	 max. - min. ≤ 0,20 mm ∅ ± 0,10 mm
Height Variation (mm)	 ∅ ≤ 0,10 mm max. 0,15 mm
Edge Straightness (mm)	 ≤ 0,30 mm
Flatness	Width Flatness, concave < 0.15%, convex < 0.20% Length Flatness, concave < 0.50%, convex < 1.0%

Packaging Information					
	Length (mm)	Width (mm)	Thickness (mm)	Sq. ft. per Carton	Weight (lb. per carton)
Plank	Assorted Lengths 630 - 1900	190	18		
Carton	1910	200	118	23.5	56

Pallet Information					
	Length Width Height (mm)	Volume (m³)	# of carton per Pallet	Sq. ft. /pallet	Weight (lb.)
Pallet	1910 1000 960	1.8336	40	940	2240